

Want to Install It Yourself?



**Kitsap County Public Works
Wastewater Division**

October 2006

Want To Do It Yourself?

Kitsap County Code provides that Side Sewer contractors licensed by the County or the owner of the property may install building sewers. The building sewer is only that portion that lies between the County right-of-way and the build. Only Licensed Side Sewer Contractors can perform work within the County right-of-way. The attached Detail PD-9 shows the relationship between a side sewer and a building sewer. It also provides general construction information.

Because the work can be strenuous and dangerous, the County strongly recommends that you hire a contractor from the attached list to do the work. However, if you feel that you are up to the challenge, this brochure will provide you with the information you will need to do the job in accordance with County Standards.

Before you start digging you will need to obtain a Building Side Sewer Permit from the County and you will need to know where you can connect to the sewer. The permit and sewer location information can be obtained from Wastewater Engineering personnel on the third floor of the Public Works building located at 507 Austin Avenue in Port Orchard. Please call us at 337-5777 to obtain current connection fee information.

Kitsap County Code also provides that building sewers conform to the requirements of the County's Standards for Sanitary Sewer Extensions. The following are required for building sewer installations:

General Requirements

1. We only allow maximum of one residential unit or one commercial/multi-family building for each building sewer.
2. The minimum building sewer pipe size is 4-inch for a single residence and 6-inch for a commercial or multi-family service.
3. We do not allow connections to the building sewer from downspouts, gutters, basement sump pumps, outside drains, or any other feature receiving or exposed to rain or groundwater.
4. Underground Utility Locations – You will need to contact the Utilities Underground Location Center (Call Before You Dig), 1-800-424-5555, a minimum of two days prior to commencing work. *(This will show you if there are any underground utilities such as power, telephone, gas, water, etc. where you are planning to dig.)*
5. Kitsap County requires that one of our inspectors inspect all building sewer installations and witness all test procedures. We also require that you notify the inspector a minimum of two working days in advance of commencing work. Final acceptance of building sewer installations will not be made until tests and inspections are complete and prove satisfactory. Copies of our inspectors' business cards are attached. You may also contact Nancy Brotzel at 337-5777 to schedule an inspection. *(We also strongly recommend that you schedule an appointment with one of inspectors to discuss your project before you start. They*

can answer your questions and they may have ideas on how to make the job easier. Unlike most doctors, they do make house calls.)

Material Requirements

1. Because it's durable and easy to install, polyvinyl chloride (PVC) is the most suitable pipe for most building sewers. However, PVC pipe should not be installed less than 18-inches below finished grade. The County requires that PVC pipe meet ASTM D 3034, SDR 35 specifications.
2. Joints for PVC sewer pipe must be push-on type with restrained elastomeric ring gaskets conforming to ASTM D 3212 or rubber gaskets conforming to ASTM F 477.
3. Fittings, such as tees and elbows, shall be PVC plastic having a cell classification of 12454-B, 12454-C, or 13343-C, as defined in ASTM D 1784. The fittings must have sufficient strength to withstand handling and load stresses normally encountered with installation.
4. In locations where 18-inches of cover is not possible, ductile iron pipe should be installed. We require that ductile iron pipe conform to AWWA C 151, Class 50 specifications and shall be cement mortar lined, with either push-on joints or mechanical joints.
5. Joints for ductile iron must be rubber gasketed conforming to the requirements of AWWA C 111.
6. Cleanouts should be constructed of the same material as the building side sewer. Cleanout boxes and covers can be polyethylene plastic.
7. Pipe bedding – Our inspectors prefer that you use pea gravel under and around the pipe (See Trench Detail Below). Pea gravel is easy to work with and requires no compaction.

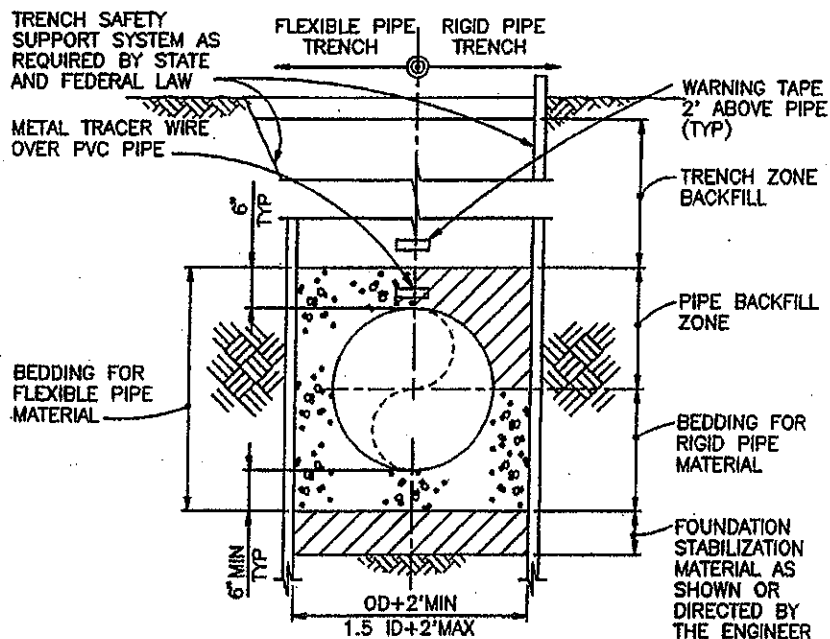

Construction Requirements

1. Minimum grade is 2%. Special circumstances may require consideration of grades less than 2% but will require approval of the County.
2. Maximum grade is 45%. Grades in excess of 45% will be considered only to resolve exceptionally steep site conditions and only with the installation of pipe anchors at no more than 16-foot centers.
3. Any trench that exceeds 4 feet in depth must meet all the applicable health and safety standards required by the Occupational Safety and Health Act (OSHA) and the Washington Industrial Safety and Health Act (WISHA). *(If you need to dig deeper than 4 feet to install your building sewer, we strongly advise that you consider hiring a Licensed Side Sewer Contractor to do the work. They have the equipment and expertise to install the sewer safely.)*
4. A test tee must be installed at the end of the side sewer and a plug inserted in the downstream side of the tee. The building sewer must then be connected to the test tee and extend to the building to be served. *(See construction note 1 on Detail PD-9.)*
5. The building sewer must be laid up grade from the connection point at the side sewer to the building plumbing connection point, with the bell end pointed upgrade.
6. Cleanouts must be installed at 100-foot spacing on straight building sewer alignment and at all fitting combinations within total change in direction of more than 45 degrees. If the combinations of bends have a straight pipe 4 feet or greater between the bends it is not considered a change in direction.
7. Building sewer cleanouts must be of the same diameter as the building sewer and be extended to a point not less than 4 inches nor more than 12 inches below finished grade. They must be plugged with a removable threaded watertight plug.

Testing

1. Before you backfill the trench you must test the pipe for leaks using a water test that is witnessed by the County inspector.
2. First, plug the pipe at the upstream portion of the test tee at the connection point *(See construction note 1 on Detail PD-9)* using either an approved adjustable sewer plug or an inflatable sewer ball.
3. Install a 4-foot standpipe on the cleanout where the building sewer will be connected *(See construction note 6 on Detail PD-9)* and fill with water to the top of the standpipe.
4. The pipe test is considered successful if there is no detectable loss of water after a minimum of 15 minutes.
5. Upon the satisfactory testing of the pipe, the building plumbing can be connected to the building sewer.

Backfilling

After successfully passing the water leakage test you can backfill the pipe with pea gravel (approximately 6" above the pipe) and fill and compact the trench with the native material removed during excavation.

Helpful Tips

1. To determine the slope required for the pipe divide the difference in elevation between the bottom of the connection cleanout and the bottom of the building plumbing pipe at the house connection and then divide by the distance between the two points, then divide that by 100. (*Example: If the connection cleanout is approximately 2 1/2 feet below the building connection and they are 50 feet apart.* $\frac{2.5}{50} \times 100 = 5\%$).
2. One method of making sure that your pipe is laid at a 2% grade is to tape a 1/2" shim on the end of a 2- foot long carpenters level. Add an additional 1/4" of shim for each additional percent of grade, 3/4" = 3%, 1" = 4%, 1 1/4" = 5%, etc.
3. Backfill your trench in 6-inch lifts and compact each lift. The better you compact the trench backfill the less settlement you will have.

Properly installed, your building sewer should provide many years of trouble free service. You can help by not pouring fats, oils or grease down your sink. Avoid planting trees over or near the building sewer because the roots could eventually work their way through the pipe joints.

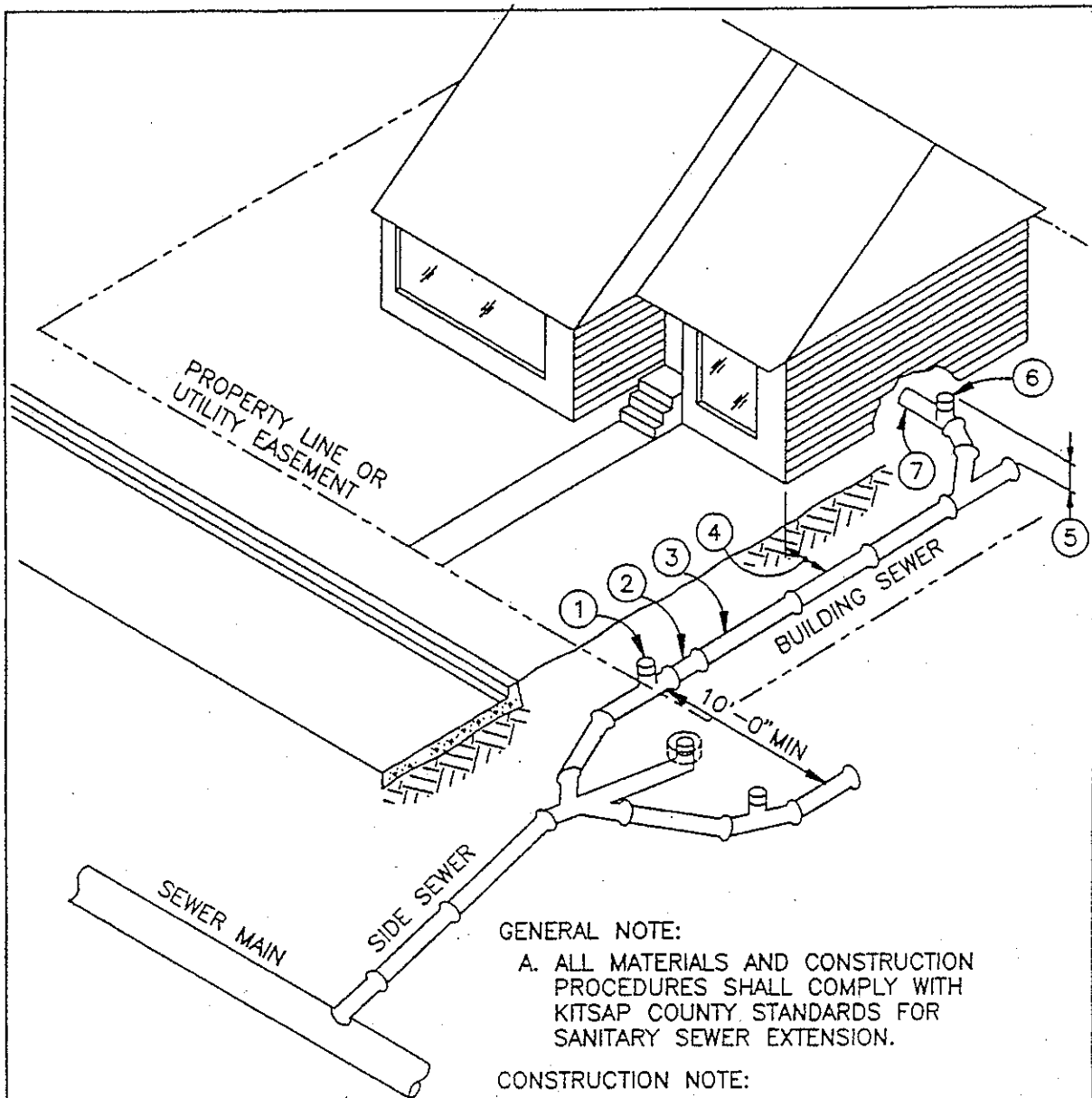

GENERAL NOTE:

A. ALL MATERIALS AND CONSTRUCTION PROCEDURES SHALL COMPLY WITH KITSAP COUNTY STANDARDS FOR SANITARY SEWER EXTENSION.

CONSTRUCTION NOTE:

- ① 6" x 6" x 6" TEE BELOW GRADE
- ② 6" x 4" REDUCER
- ③ 4" BUILDING SEWER
- ④ 30" MINIMUM FROM BUILDING
- ⑤ 18" MINIMUM DEPTH
- ⑥ CLEANOUT WITH THREADED PLUG
- ⑦ RUBBER COUPLING AT BUILDING

BUILDING SEWER CONNECTION

NO SCALE

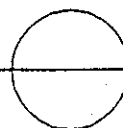

2585003/KCPW2 12.95

KITSAP COUNTY
Dept. of Public Works

BUILDING SEWER
CONNECTION

DETAIL
PD-9